

Rectangular emergency overflow

Attention: The processing instructions of the roofing membrane manufacturers must be observed; Materials and material compounds used may be subject to changes

Function:

Moulded part for horizontal drainage or emergency drainage through the parapet. When installing, the exact installation point must be chosen depending on the water height.

Material:

Variants PVC and FPO/PP² for connection to the respective matching material variant of the roofing membrane. Use for connecting to bituminous waterproofing with liquid-applied waterproofing. The materials are modified to be weather-resistant: UV-stabilised, resistant to heat degradation and oxidative ageing as well as cold impact resistant.

Available sizes (W x H – inner dimensions):

- 120 x 60 mm • 300 x 80 mm • 500 x 100 mm • 750 x 100 mm
- 180 x 80 mm • 300 x 100 mm • 600 x 100 mm • 1000 x 100 mm

Available lengths (l):

- 300 mm • 600 mm

Colours:

- PVC similar to RAL 7047, Telegrey 4
- FPO/PP similar to RAL 7044, Silk Grey

Packaging units:

Delivery in box, PU 1 piece

Accessories:

- Vapour barrier sheet

Drainage capacity:

LGA-certified performance data

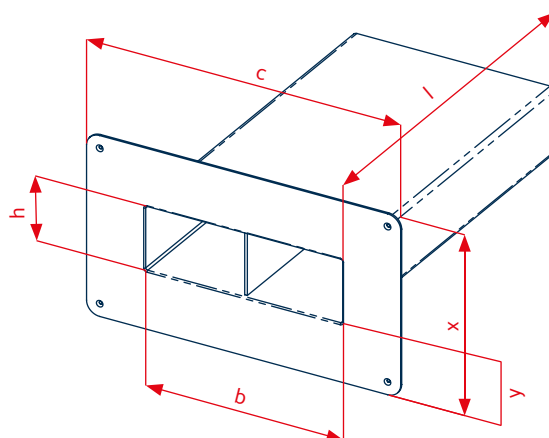

Channel = W x H ¹	Attenuation depth	
	35 mm	65 mm
120 x 60 mm	1.30 l/s	3.50 l/s
180 x 80 mm	1.90 l/s	5.00 l/s
300 x 80 mm	3.00 l/s	7.80 l/s
300 x 100 mm	3.00 l/s	7.80 l/s
500 x 100 mm	5.50 l/s	13.40 l/s
600 x 100 mm	5.80 l/s	n/a
750 x 100 mm	7.50 l/s	19.20 l/s
1000 x 100 mm	12.60 l/s	29.40 l/s

Technical data					
Channel = W x H ¹	b	h	c	x	y
120 x 60 mm	120 mm	60 mm	300 mm	240 mm	90 mm
180 x 80 mm	180 mm	80 mm	360 mm	260 mm	90 mm
300 x 80 mm	300 mm	80 mm	480 mm	260 mm	90 mm
300 x 100 mm	300 mm	100 mm	480 mm	280 mm	90 mm
500 x 100 mm	500 mm	100 mm	680 mm	280 mm	90 mm
600 x 100 mm	600 mm	100 mm	780 mm	280 mm	90 mm
750 x 100 mm	750 mm	100 mm	930 mm	280 mm	90 mm
1000 x 100 mm	1000 mm	100 mm	1180 mm	280 mm	90 mm

Pipe inclination each 5°

¹Special sizes available on request / ²Also available in PE (roofing membranes based on PE)
 KALA - KUNSTSTOFFE | Karl-Heinz Lange GmbH+Co.KG reserves the right to make technical changes.