

Gravel guard Vario Fix continuously adjustable for drains and gullies

Function:

Moulded part as attachment for drain or gully. Serves to retain coarse dirt particles and prevent clogging of the waste water system. Its flow-optimised geometry ensures low loss values and high flow throughput, even during heavy rain – LGA-certified.

Installation:

The product is ready for installation. Place the gravel guard centrally on the drain or gully, press the locking button down and turn to the right to lock. The expansion grip can be continuously adjusted to the diameter of the drain or gully using the turning mechanism. To remove it later, simply turn the rotary knob to the left again to unlock it and pull it out. The expansion grip can then be pressed together again.

Material:

- PE Black
- Cold impact resistant, weather-resistant, UV-stabilised

Available sizes:

For all diameters from D 50 mm (DN 50) to D 160 mm (DN 150)

Packaging units:

Delivery in box, PU 10 pieces

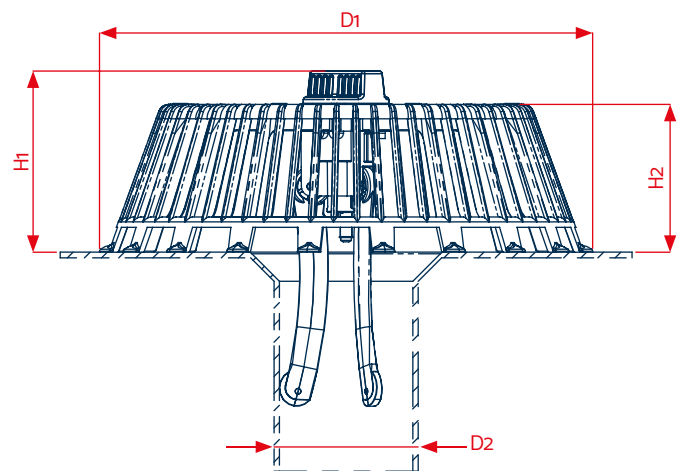

Fixed in no time:

1. Insert



3. Locking



2. Press



Technical data	
H1	95 mm
H2	77.5 mm
D1	262 mm
D2	D 50 mm (DN 50) - D 160 mm (DN 150)

KALA - KUNSTSTOFFE | Karl-Heinz Lange GmbH+Co.KG reserves the right to make technical changes.