

Gravel basket Classic with centering cross for drains and gullies

Function:

Moulded part as attachment to a drain or gully. Serves to retain coarse dirt particles to stop the drainage system from clogging up. The LGA-certified, flow-optimised design ensures minimal loss of flow and high performance, even during torrential rain.

Installation:

Shorten the four wings on the centering cross to match the inner diameter of the drain or gully, slightly oversize and simply press in. The cutting mark on all four wings makes it easy to cut them exactly to size. Fits all standard drains and gullies up to DN 150.

Material:

- PE Black
- Low-temperature impact resistant plastic, weatherproof, UV-stabilized

Available sizes:

Suitable for all diameters ranging from D 50 mm (DN 50) to D 160 mm (DN 150)

Package units:

Supplied in cartons, PU 10 units

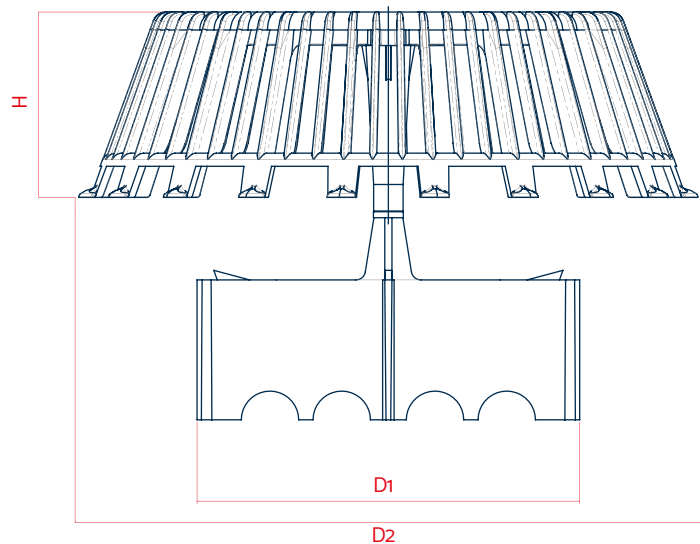

Technical data		
H	77,5	mm
D1	160	
D2	262	