

# Gravel basket Vario Fix variably adjustable for drains and gullies

## Function:

Moulded part as attachment to a drain or gully. Serves to retain coarse dirt particles to stop the drainage system from clogging up. The LGA-certified, flow-optimised design ensures minimal loss of flow and high performance, even during torrential rain.

## Installation:

The delivery is ready for installation. Place the gravel basket centrally on the drain or gully, press the locking button down and turn it to the right to lock - done. The spreading feet can be continuously adjusted to the diameter of the drain or gully with the turning mechanism. For later removal, simply turn the knob to the left again to unlock and pull out. When unlocked, the spreader feet can simply be pressed together again.

## Material:

- PE Black
- Low-temperature impact resistant plastic, weatherproof, UV-stabilized

## Available sizes:

Suitable for all diameters ranging from D 50 mm (DN 50) to D 160 mm (DN 150)

## Package units:

Supplied in cartons, PU 10 units

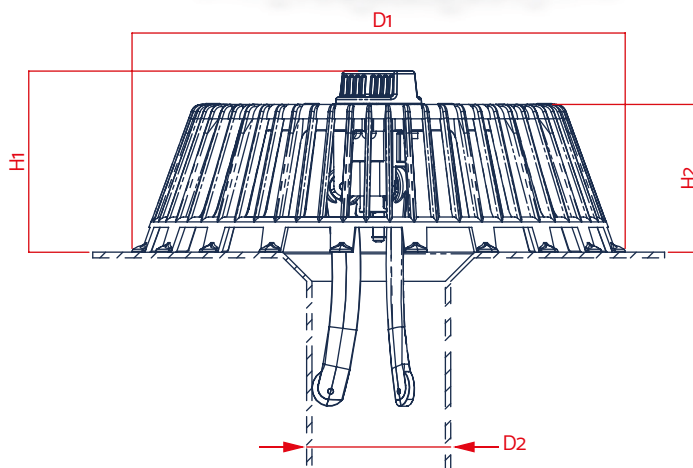

Technical data		
H1	95	mm
H2	77,50	
D1	260	
D2	D 50 - D 160	

## Fixed in the blink of an eye:

### 1. Insert



### 2. Press



### 3. Lock

