

H-MAX terrace support system

Function:

Terrace support for the installation of all surface types, particularly stone slabs and boardwalk finishes. The height adjustment and optional equalizing elements permit easy levelling of surfaces and slopes. Additional protective mats must be fitted in areas frequented by the public, such as entrances to public buildings, cafeterias, etc.

Versions:

- 3 mm wide joint dividers
- With snap-off wings

Package units:

Supplied in cartons, PU 25 units

Accessories:

- ProSilent equaliser disc for terrace support systems, splits into quarters, D 112 mm

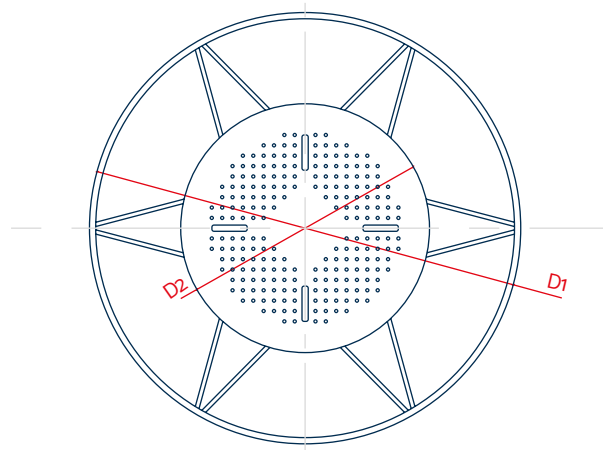
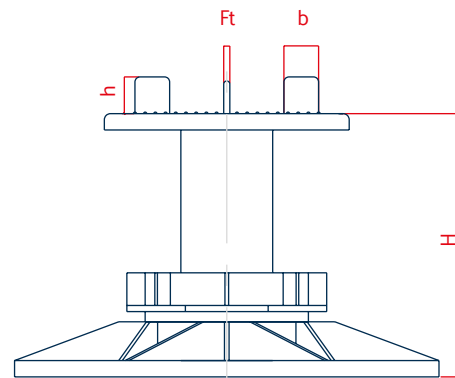

Technical data						
	65 - 100	95 - 130	125 - 160	155 - 190	185 - 220	
D1	208	208	208	208	208	mm
D2	120	120	120	120	120	
H	65 - 100	95 - 130	125 - 160	155 - 190	185 - 220	
h	18	18	18	18	18	
b	17	17	17	17	17	
Ft	3	3	3	3	3	