

Drain Nexo Fix

Attention: The processing instructions of the roofing membrane manufacturer must be adhered to; Materials and used material compounds may be subject to change.

Function:

Molding for vertical drainage through the roof package. Installation with connection to a pipe system for water drainage or as an extension element for a roof drain. Pay attention to appropriate backflow protection.

Installation:

Position the drains in the opening in the roof structure, if used as an extension element, connect them to the gully underneath, align them with the subsurface and fasten them securely at four points in the subsurface using the holes on the edge of the tray. Weld the connection sleeve to the waterproofing membrane all around professionally and in accordance with the roofing membrane manufacturer's specifications.

Material:

Versions PVC and FPO/PP with welded connection sleeve for easy connection to the appropriate roofing membrane. The material of the ground body is weatherproof modified: UV-stabilized, against heat degradation and oxidative aging as well as cold impact resistant.

Available sizes ²:

- D 50 mm (DN 50)
- D 75 mm (DN 70)
- D 90 mm
- D 95 mm
- D 110 mm (DN 100)
- D 125 mm (DN 125)
- D 160 mm (DN 150)

Package units:

Supplied in cartons, PU 1 unit

Accessories ³:

- Gravel basket
- Lip seal

Drainage performance:

LGA-certified characteristics

Diameter	Accumulation height	
	35 mm	65 mm
D 50 mm (DN 50)	3.70 litre/sec.	N/A
D 75 mm (DN 70)	4.60 litre/sec.	13.20 litre/sec.
D 90 mm	5.30 litre/sec.	14.60 litre/sec.
D 110 mm (DN 100)	5.55 litre/sec.	15.80 litre/sec.
D 125 mm (DN 125)	5.55 litre/sec.	16.00 litre/sec.
D 160 mm (DN 150)	5.60 litre/sec.	18.60 litre/sec.

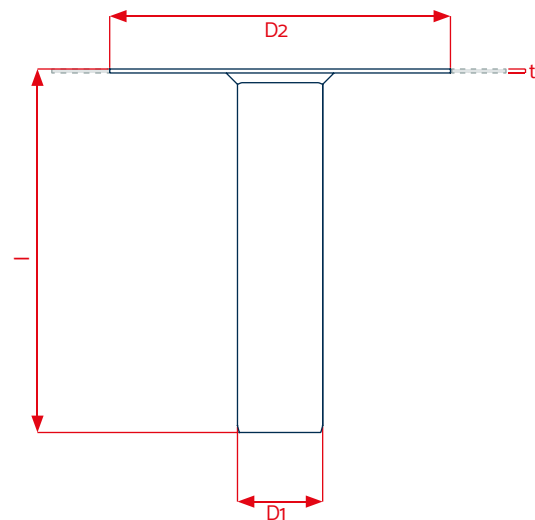
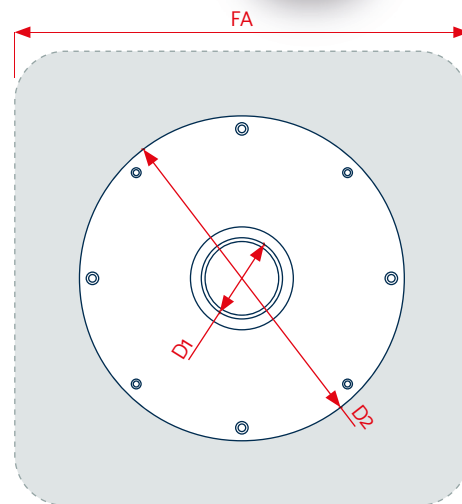

Technical data		
D1	50 / 75 mm	90 / 95 / 110 / 125 / 160 mm
D2	300 mm	380 mm
l	320 mm ¹	320 mm ¹
t	35 mm	35 mm
Foil connection (FC)	D 50 mm (DN 50) to D 75 mm (DN 70)	L 500 x W 500 mm
Foil connection (FC)	D 90 mm to D 160 mm (DN 150)	L 580 x W 580 mm

¹Special lengths available on request / ²Other diameter sizes available on request / ³Alternatively also available with accumulation ring
KALA - KUNSTSTOFFE | Karl-Heinz Lange GmbH+Co.KG reserves the right to make technical changes.